

MECHANICAL DEVICE BUILDER

Datasheet

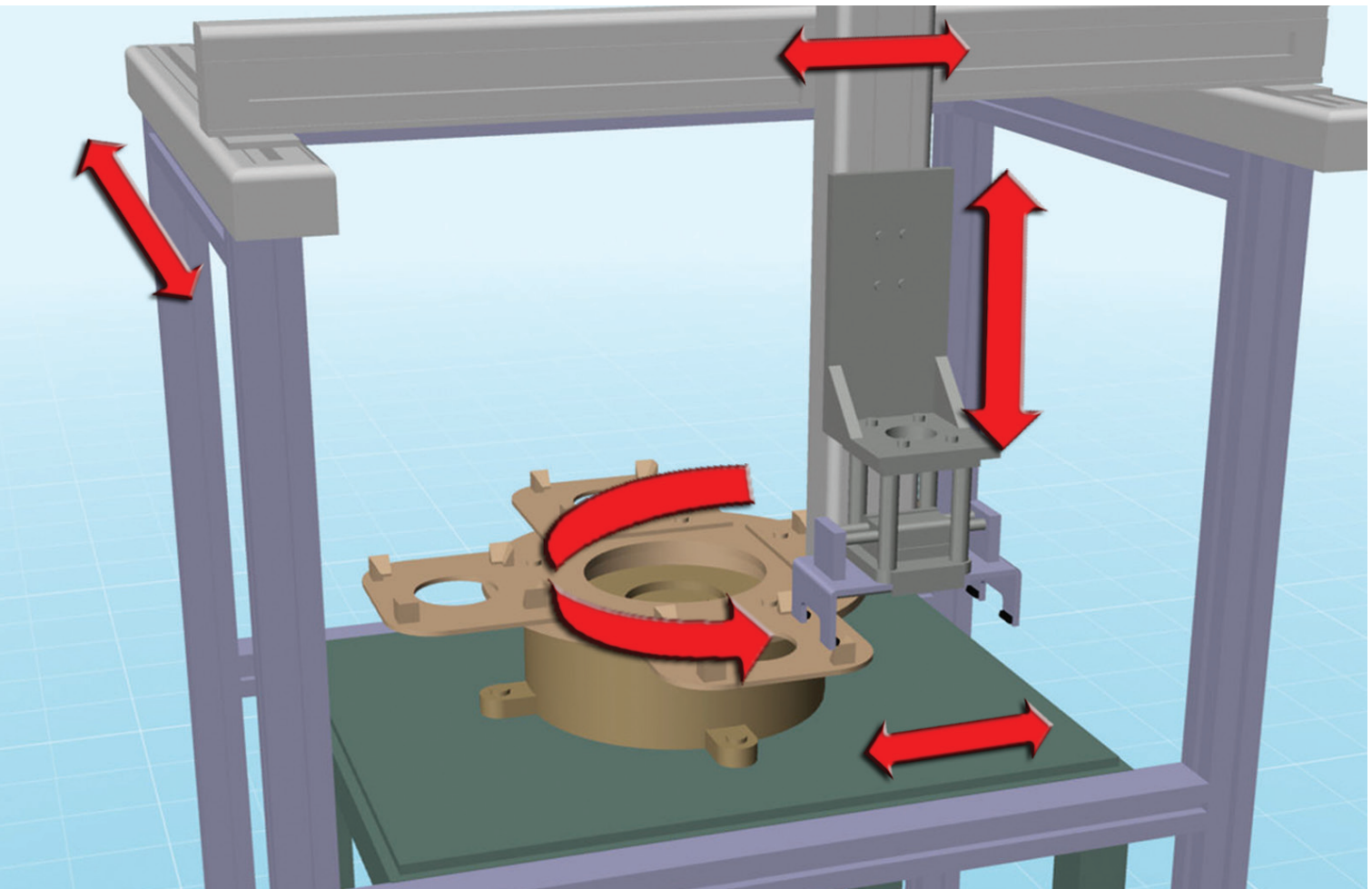

**DEFINE MECHANICAL DEVICES
FOR USE IN 3D PROCESS
PLANNING AND VALIDATION:**

DELMIA MECHANICAL DEVICE
BUILDER ENABLES USERS TO
DISCOVER ISSUES EARLY IN
THE DESIGN CYCLE, SUCH AS
INTERFERENCES, TRAVEL LIMITS,
AND REACHABILITY.

DELMIA Mechanical Device Builder (MDB) delivers the ability to create virtual mechanical devices for use in downstream planning and simulation activities. Resource designers can leverage the intuitive user interface to define all types of mechanical devices that would be used in a manufacturing setting, from simple clamps to complex robots and lift-assist equipment. Once a device model is validated, it can be saved to a resource catalog for use by planners, programmers, and simulation engineers as they define, optimize, and validate their manufacturing plans.

CREATE AND VALIDATE KINEMATIC MODELS OF MANUFACTURING DEVICES

DELMIA Mechanical Device Builder provides a collection of easy-to-use tools for the creation of both forward and inverse kinematic devices. A library of mathematical functions allows the user to easily create equations when modeling advanced devices. Users are able to jog each individual joint or move the device's "Tool Center Point" in 3D to validate the kinematic definition.

CREATE MECHANICAL JOINTS BASED ON AXES SELECTION

This powerful feature is used to create devices based on CAD part and assembly definitions. Tools are provided to create mechanical joints (revolute, prismatic, etc.) by selecting frames on the appropriate parts.

DEFINE MOTION CONTROLLER AND MANAGE MOTION GROUPS

Users can define motion controller and motion groups. This enables the coordinated motion of resources such as a robot, a mounted weld gun and an external positioning table working in tandem in a spot welding scenario.

PRODUCT HIGHLIGHTS

- Create forward and inverse kinematic devices
- Customize controller profiles
- Synchronize updated resource motion controller for all device instances
- Define the work envelope for robot devices
- Automatically redefine the "Tool Center Point" when tooling is attached
- Assign inverse kinematics to manufacturing devices
- Define home positions and joint travel limits

About Dassault Systèmes

Dassault Systèmes, the **3DEXPERIENCE** Company, provides business and people with virtual universes to imagine sustainable innovations. Its world-leading solutions transform the way products are designed, produced, and supported. Dassault Systèmes' collaborative solutions foster social innovation, expanding possibilities for the virtual world to improve the real world. The group brings value to over 150,000 customers of all sizes, in all industries, in more than 80 countries. For more information, visit www.3ds.com.

The 3DS logo, CATIA, SOLIDWORKS, SIMULIA, DELMIA, ENOVIA, GEOVIA, EXALEAD, NETVIBES, 3DSWYM and 3DVIA are either trademarks or registered trademarks of Dassault Systèmes or its subsidiaries in the US and/or other countries.

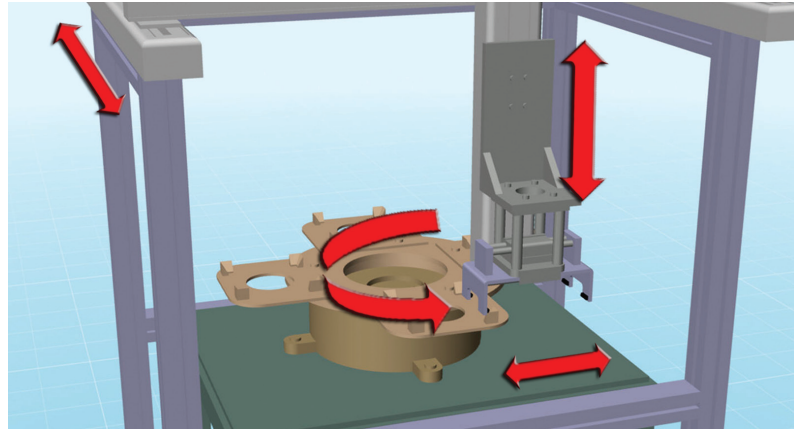

Machines are modeled with the flexibility to define relational functions for joint motion, create and edit home positions, and control speed and acceleration.

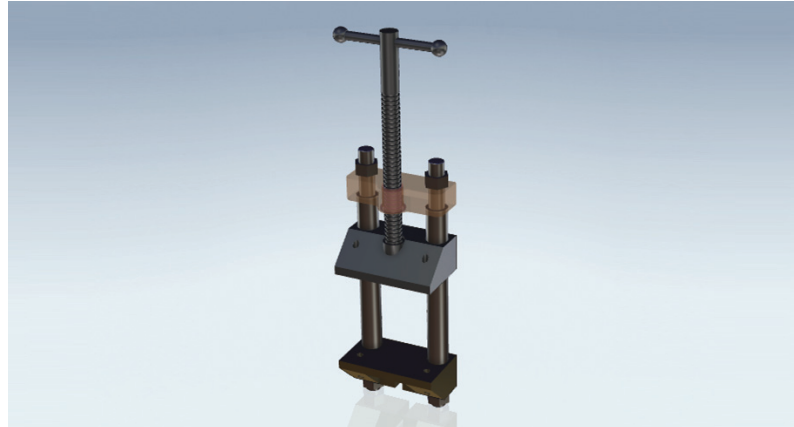

Rotating screw joints are supported, resulting in linear motion relative to the rotation of the screw.