

TOYOTA MOTORSPORT

Doubling design productivity with V5 PLM





Toyota Motorsport Objectives

- Optimize car performance by designing and testing more car components between F1 bi-weekly races**
- Comply with evolving FIA* regulations**
- Reduce development costs by optimizing processes**
- Implement Toyota's Kaizen philosophy of continuous improvement**



"Toyota Motorsport GmbH has one clear goal which is to be world champion. To achieve this, we need to continuously improve the development of the F1 car to reach the highest performance on the track."

Tsutomu Tomita, Chairman and Team Principal, Toyota Motorsport GmbH

*(FIA) Fédération Internationale de l'Automobile

Company Overview

Panasonic Toyota Racing is the official name for Toyota's Formula 1 Team. Established in 2001, the team is run on behalf of Japan's Toyota Motor Corporation by Toyota Motorsport GmbH. 2005 is Toyota's fourth season in Formula 1, making it one of the youngest teams on the grid.

With more than 600 staff from 32 different nations, Toyota Motorsport has developed its complete Formula 1 car – chassis and engine – from scratch under one roof at its factory in Cologne, Germany. Toyota's long-term goal is to beat the more established teams in Formula 1 and become a world championship constructor.

Business Challenges

Toyota Motorsport GmbH was created to strengthen Toyota Motor Corporation's awareness and image. Its purpose is to demonstrate to a large public that Toyota is a cutting-edge brand determined to attain its "One Aim" goal: to be number one.

To that end, Panasonic Toyota Racing must win races and ultimately the Constructors' Championship to gain media exposure. This means that for each and every race, Toyota Motorsport GmbH must provide its two drivers with the fastest car possible, respecting the tight, two-week race schedule.

To achieve its objectives, one of Toyota Motorsport GmbH business challenges is to quickly adapt car design to upcoming racing conditions, such as circuit configurations, driver racing style, and weather conditions. Moreover, the team must comply with the seasonal changing FIA* regulations. It must accomplish all of this within a defined budget. Therefore, mastering the cost of car development is also a priority.

Finally, Toyota Motorsport GmbH has to implement Toyota's Kaizen philosophy of continuous improvement by always pushing the limits of technical innovation and reaching excellence in all domains.

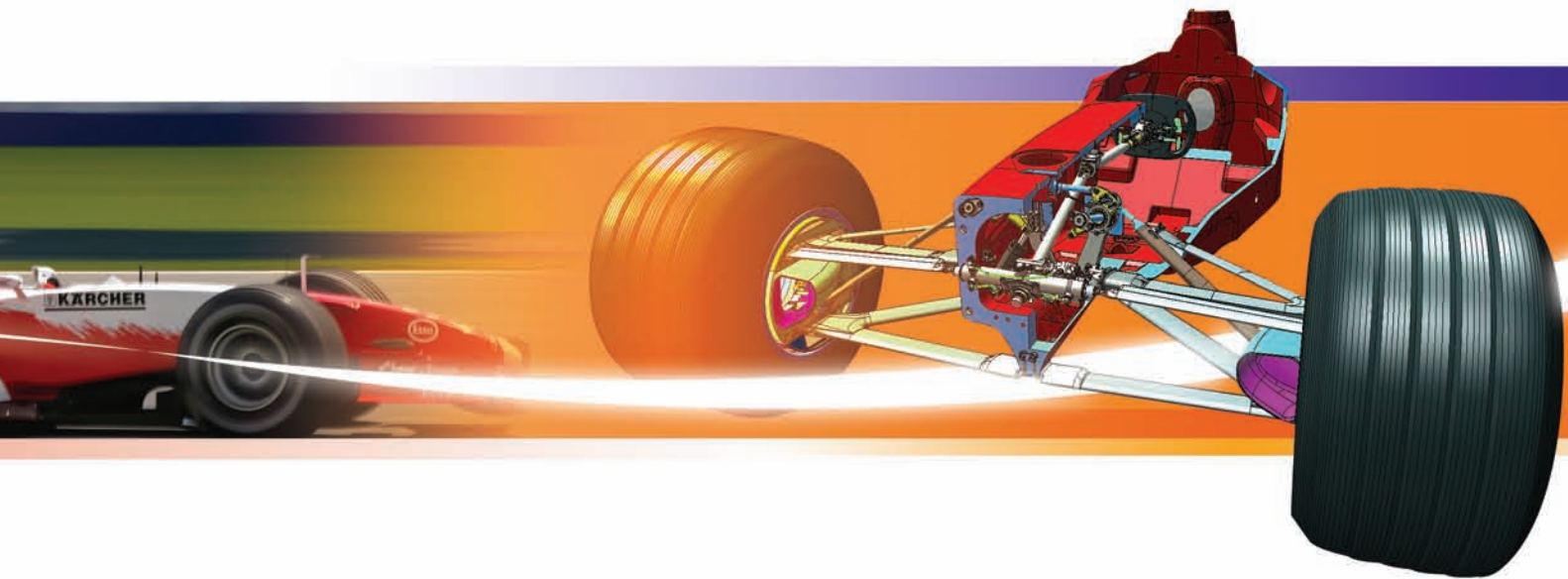

Solution

In order to face its business challenges, Toyota Motorsport GmbH chose Dassault Systèmes (DS) Version 5 Product Lifecycle Management (V5 PLM) solutions. “We needed a long term PLM solution that covers our entire development process, as well as a partner capable of understanding our job,” said Thomas Schiller, General Manager, IT department, Toyota Motorsport GmbH.

CATIA V5 to optimize car performance

The Design Department uses CATIA V5 to speed up the process of ‘getting the right part on the track’. CATIA V5’s mechanical and surfacic design tools are used in a hybrid modelling way in conjunction with CATIA V5 analysis and simulation products.

In addition, engineers appreciate CATIA V5’s ease of use. “Designers say that they have fun working with CATIA V5!” said Markus Schwarze, Manager, Technical Applications, Toyota Motorsport GmbH.

ENOVIA to streamline collaboration

To support its continuously-evolving F1 car design, the design office needs to manage all development data and make it instantaneously accessible to the entire team. ENOVIA is the virtual product development environment where all designers, production, and track teams can share the more than 8,500 up-to-date car parts.

Moreover, ENOVIA links the virtual and real worlds. “Thanks to the openness of ENOVIA, we have an ERP interface. We automatically transfer all our master data and bills of material from ENOVIA to SAP,” said Markus Schwarze.

Generative Car Solution to accelerate F1 car development

To concentrate on the car improvements and shorten the design modification process, Toyota Motorsport GmbH implemented DS Generative Car Solution with the support of Dassault Systèmes Services (DSS), the services organization of DS.

Open V5 PLM ecosystem to fully cover virtual processes

Specialized applications from DS’ CAAV5 Software partners are used for specific design, manufacturing and simulation needs such as ABAQUS for CATIA V5 for nonlinear simulation, and LMS Virtual.lab Motion for dynamic motion simulation.



“In F1 racing, you have just two weeks to cover the complete development cycle in between races. Therefore, you need a comprehensive set of tools that constitute an end-to-end collaborative car development solution. That’s V5 PLM.”

Thomas Schiller, General Manager,
IT department, Toyota Motorsport GmbH



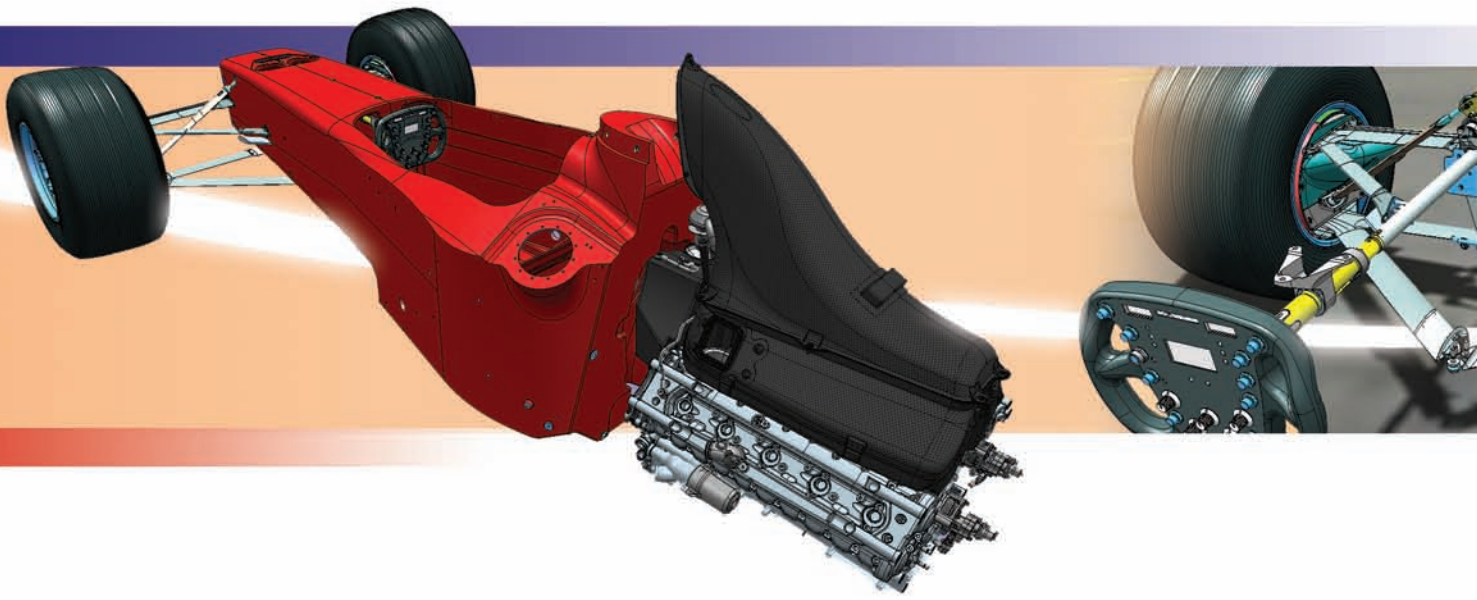

“Ultimately, when you win races, you win them in the design area. Getting new ideas into the car is key when you’re working on a two-week timeframe. That’s where Dassault Systèmes V5 PLM solutions are absolutely critical to our core functions.”

Mike Gascoyne, Technical Director Chassis,
Toyota Motorsport GmbH

Results

Toyota Motorsport has achieved clear and tangible benefits from its V5 PLM implementation throughout its entire development process:

Chassis process: time gains

Excellence in racing car design is the result of tremendous homogeneity between the chassis and the engine. The V5 PLM Digital Mock-Up (DMU) tools, native to CATIA and ENOVIA, are critical to achieving this harmony. “By using V5 PLM DMU solutions, we can check the car’s assembly while we’re still in the design stage, because the designers are not designing in isolation,” said Mike Gascoyne, Technical Director Chassis, Toyota Motorsport GmbH. “We simply don’t see the problems that we used to have in terms of car’s first physical assembly. This could take previously maybe two or three weeks. We now do it in two or three days. This time gain is a tremendous advantage for us.”

Moreover, Toyota Motorsport GmbH automatically programs its laser-cutting robots with CENIT’s FasTRIM CAA V5 Based product (built on the DELMIA architecture) from CATIA models. This has doubled the speed and halved the cost of the laser-cutting process.

Aerodynamics process: productivity gains

The aerodynamics team, part of the chassis department, has a specific objective: design and test a maximum number of wind tunnel prototypes to find the optimal car component. “Moving from CATIA V4 to CATIA V5 has enabled us to almost double the number of prototypes we can make in a given time,” said Mike Gascoyne. “This in turn enables us to double the number of tests in the wind tunnel and double the car aerodynamic performance. That’s absolutely essential to high performance on the track!”

Another benefit measured by Toyota Motorsport GmbH’s aerodynamics team comes from the implementation of the Generative Car solution. “The implementation of the Generative Car solution in the aerodynamics department has increased design productivity by 30%, and by up to 80% if we look at parts such as the front wing,” said Stéphane Chosse, Wind tunnel Model Design Manager, Aerodynamic department, Toyota Motorsport GmbH. “This was a real big step for us. It gave us the possibility to design quicker and therefore design more.”



V5 PLM Key Benefits

Engine process: design quality improvement

The powertrain challenge lies in producing the most powerful engine while keeping it as lightweight and reliable as possible. "Design quality is the key issue to a successful Formula 1 car engine," said Luca Marmorini, Technical Director Engine, Toyota Motorsport GmbH. "CATIA V5 analysis tools offer us the chance to simulate the constraints endured by extremely complex models, such as blocks or crankshafts. This definitely helps us increase the engine's design quality."

Moreover, following the analysis simulation stage, the design modification phase is faster thanks to CATIA V5 knowledge-based architecture. It allows designers to capture design intent as well as easily modify parameters. Thus, updating a part becomes quite instantaneous.

Car transmission process: time savings

Toyota Motorsport GmbH has made very significant time gains in the development of its car transmission since upgrading from CATIA V4 to CATIA V5. "CATIA V5 implementation in the transmission area was very impressive," said Thomas Schiller. "It took us as much time to implement, train people, and design the car transmission in CATIA V5 as it took us just to design it in CATIA V4. Plus, we were able to double design and analysis iterations!"

Cockpit ergonomics: innovation in F1 conductivity

Formula 1 drivers perform in a very stressful environment where cornering exerts forces between four to five G's (equal to a military jet cockpit). To focus on performance, the driver must be in the safest and most comfortable position. CATIA V5 enables engineers to design the car in a way that optimizes its interactions with the pilot.

"With CATIA V5 Human Modelling ergonomics tools, we insert the pilot virtually into the digital mock-up of the car," said Mike Gascoyne. "We can then optimize the ergonomic design of the monocoque to ensure that the driver will fit perfectly and be able to operate the car while driving it at the limit."

Time reduction

Up to **-80%** time in the aerodynamics design process (Generative Car solution)

-90% time for the car first physical assembly from 3 weeks to 2 days (V5 PLM DMU)

-15%* time to create Bills of Material (BOM)

Improved car performance

+100% wind tunnel prototypes' production and test (Knowledge-based designs)

One of the most reputed F1 engine (the department has moved to CATIA V5)

Costs Reduction

-60%* costs and time spent searching for information during design processes

-40%* cost for fixing BOM errors

-48%* cost for administering Engineering Change Requests (administration, tracking, distribution, etc.) and **-57%*** labor costs to complete ECRs

*findings based on an independent study performed by CIMdata, PLM consultant.



“Reliability is a serious issue in Formula 1. So, we need a very flexible system to modify and update parts. This is why Dassault Systèmes solutions offer us a good opportunity to be really aggressive.”

Luca Marmorini, Technical Director Engine,
Toyota Motorsport GmbH

Extended collaboration around the digital mock-up

With CATIA V5 and ENOVIA, Toyota Motorsport GmbH has a virtual Formula 1 development hub where any team member can access the car’s digital mock-up. For instance, every person on the shopfloor and in the assembly workshop uses V5 PLM DMU tools to see in 3D the parts they have to produce.

In addition, the car’s digital mock-up can be accessed by the purchasing or marketing departments in order to perform specific tasks in CATIA V5. “In our marketing department, we use CATIA V5 Real Time Rendering to get an idea of what the car will look like before we build it,” said Markus Schwarze. “It is absolutely essential for our sponsors to see what millions of people will see on TV screens before the car is on the track.”

Furthermore, the digital mock-up enables Cologne-based engineers to collaborate with the parent company Toyota Motor Corporation in Japan on the design and manufacture of particularly complex parts.

Finally, V5 PLM solutions are present on the circuits. “By using CATIA V5 and ENOVIA, the track mechanics are able to see, in 3D, how they have to fit all the car components,” said Mike Gascoyne.



Future

In order to support its Kaizen philosophy, Toyota Motorsport GmbH will continue to enhance its use of V5 PLM solutions.

In particular, Toyota Motorsport GmbH is considering adopting the CATIA V5 Composites solution. "By using CATIA V5 composites tools, we expect to reduce by 20% overall design-to-production process time," said Thomas Schiller.



"We view all partnerships, and in particular the one we have with Dassault Systèmes, as a win-win opportunity. Dassault Systèmes offers us car development solutions that give us the cutting-edge performance that is required in Formula 1. At the same time, we like to think we're pushing their technology to new limits because of the ultimate challenge of material and performance that Formula 1 demands."

John Howett, President, Toyota Motorsport GmbH

V5 PLM FOR THE AUTOMOTIVE INDUSTRY

DS has been working with major automotive manufacturers and suppliers for more than 20 years to provide a range of leading PLM solutions.

Built from industry experience and addressing all key automotive development domains, Generative Car Solutions combine the best of Dassault Systèmes' CATIA V5, DELMIA, ENOVIA and SMARTEAM products with dedicated automotive best practices.

Fostering the capture, sharing and reuse of company knowledge while optimizing the end-to-end process from concept to maintenance,

DS Generative Car Solutions help automotive manufacturers and suppliers to considerably reduce design cycle time and increase productivity, profitability, and rapid return on investment.

For information about DS Generative Car Solutions, visit www.3ds.com

The Dassault Systèmes home page can be found at www.3ds.com

Dassault Systèmes
9, quai Marcel Dassault
BP 310
92156 Suresnes Cedex
France

As world leader in 3D and PLM (Product Lifecycle Management) solutions, the Dassault Systèmes group brings value to more than 80,000 customers in 80 countries.

A pioneer in the 3D software market since 1981, Dassault Systèmes develops and markets PLM application software and services that support industrial processes and provide a 3D vision of the entire life cycle of products from conception to retirement.

Dassault Systèmes V5 PLM offering includes integrated solutions : CATIA, DELMIA, ENOVIA and SMARTEAM. CATIA® is a registered trademark of Dassault Systèmes.

DELMIA® is a trademark of Dassault Systèmes.

ENOVIA® is a registered trademark of Dassault Systèmes.

SMARTEAM® is a registered trademark of SmarTeam Corporation Ltd.

Images courtesy of Toyota Motorsport GmbH.

© Copyright Dassault Systèmes 2005.

All Rights Reserved.

RF_Y_S569N_EN_200507

For more information or to contact a sales representative, visit www.3ds.com/contacts

