

CATIA PLM Express The Fastest Road to PLM



Bringing 25 Years of Product Design Excellence to Businesses of all Sizes

Our customer's challenges:

In today's business world, companies are facing tremendous pressure to retain business and win market shares. They must innovate and speed time to market, all the while becoming more flexible, improving quality, reducing costs and controlling investments.

Product Lifecycle Management (PLM) is an excellent solution, however, some companies perceive it to be complex and time consuming to successfully deploy and to get user teams trained and up-to-speed.

CATIA PLM Express fully addresses those challenges:

Designed specifically for small and medium sized businesses, it provides CATIA design excellence at an affordable price.

Based on Dassault Systèmes cross-industry expertise, it delivers

flexible solutions tailored to meet the day-to-day business needs of existing and future customers. This scalable solution is mapped to industry and job-related needs enabling companies to easily take the first steps to transform their business success through PLM. CATIA PLM Express gives customers the ability to rapidly and easily define the solution that matches their business needs and request a price quote online. Customers speed implementation, reduce deployment time and improve return on investment—critical for all businesses, regardless of industry.

The Dassault Systèmes worldwide sales channel distributes CATIA PLM Express. Existing customers can easily move to this new offering from their existing CATIA seats.



Flexible Solutions to Address Various Industry Challenges:

- Automotive
- Aerospace
- Shipbuilding
- Industrial Equipment
- High Tech
- Consumer Goods
- Consumer Packaged Goods
- Life Sciences
- Process, Power, Petroleum
- Architecture & Construction

Provided by Dassault Systèmes, the world leader in PLM, delivering compelling benefits:



"Number of new products developed in same time period +70%"



"Design quality +70%"



"Prototype costs per year -66%"



"Design modification time -80%"



"Development efficiency increased +30%"

CATIA PLM Express Delivers the CATIA Team PLM Core Configuration

CATIA Team PLM is the highest standard to reach product design excellence in multiple Industries by delivering the following values:

Ready-to-Go Team Collaboration powered by ENOVIA SmarTeam

- Native access to virtual product information directly from within CATIA
- Pre-customized product information for managing customer assets
- Reuse of existing assets
- Fully secured environment
- Collaborative design iteration
- Traceability for full product lifecycle management
- Rapid deployment of a complete collaborative environment in less than 10 days

Ultra Fast Knowledge-based Modeling

- Unique knowledge capture and reuse for innovation and fast design change
- Easy product creation, from simple to sophisticated, with powerful CATIA modeler
- Comprehensive drawing production with market leading generative drafting fully associative with 3D
- Easy and interactive decision making thru instant collaborative reviews

Scalable Platform

- 44 high valued options based on 6 roles to match your needs for growth
- Free 3D XML format for all
- Simplification of exchanges across the supply chain thanks to industry standards adoption
- 340 CAA V5 partner applications to cover highly specialized disciplines
- Easy to learn with standard and intuitive user interface



CATIA PLM Express



CATIA PLM Express is organized in 6 job-related roles

It delivers all of the functionality and benefits of CATIA, and is engineered to address the customer's specific business needs and company organization.

Industry-tailored Solution Based on 6



Layout Engineer

The preliminary design of a product begins with a comprehensive layout driven by product specifications, main dimensions and component placement. To ensure a product's feasibility, the layout engineer defines product architecture in order to prepare detailed design collaboration. With CATIA PLM Express, 2D/3D technologies are flawlessly integrated

for easy and rapid iterations in order to achieve the conceptual phase of the product and concurrently activate detailed design. Layout engineers generate templates to capture optimized design methodologies, enabling their reuse in a fully interactive approach by all designers, providing dramatic productivity gains and agility to design changes.

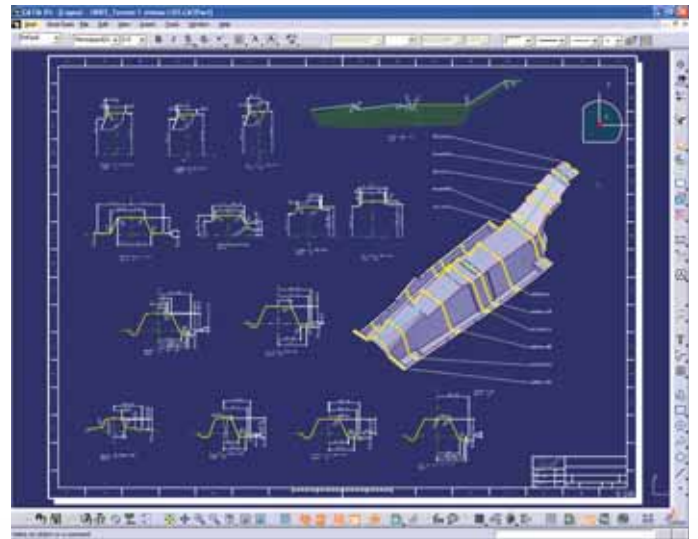

Equipment Product Engineer

Due to the growing complexity of products and the drive to reduce development time, it is critical to be able to visualize the complete virtual product, reflecting not only the mechanical components but other systems such as fluid and electrical. CATIA PLM Express enables engineers to easily define equipment such as piping,

tubing or the electrical control and power systems of the product. For example, it provides a process-oriented solution for designing physical wire harnesses driven by logical specification and is integrated with harness manufacturing. By delivering a realistic simulation for 3D wire harness packaging in an integrated environment, this powerful solution reduces design time and increases the overall quality of large-scale electrical systems.

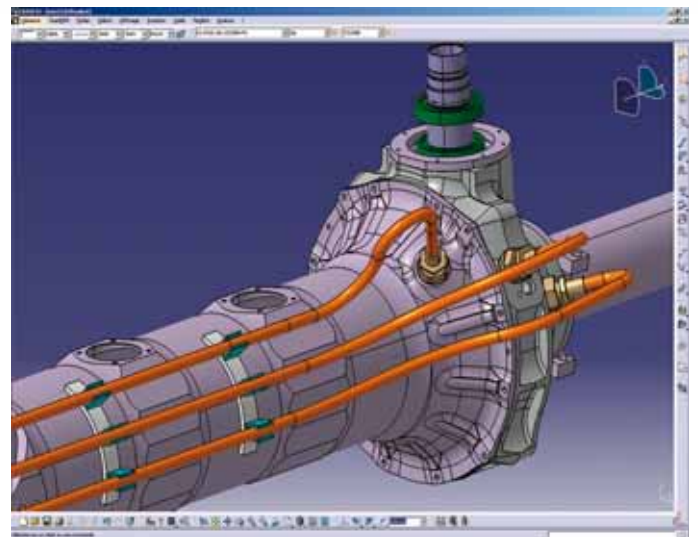

Job-related Activities to Fit Today's Bus



Styled Product Engineer

The styling aspect of a product is key to gaining immediate market excitement and interest. Creative styling is the new key to customer loyalty. Industrial designers need intuitive and easy-to-use tools to "Design at the Speed of Imagination." CATIA PLM Express fully responds to those needs, while enabling designers to work concurrently on style and engineering, or perform simulation of the product's appearance for quick style validation. It also makes it possible to quickly capture physical prototype shapes, making the 3D virtual model the design reference. Having an integrated styling process as part of the development and manufacturing process enables companies to quickly launch new ideas in the marketplace.

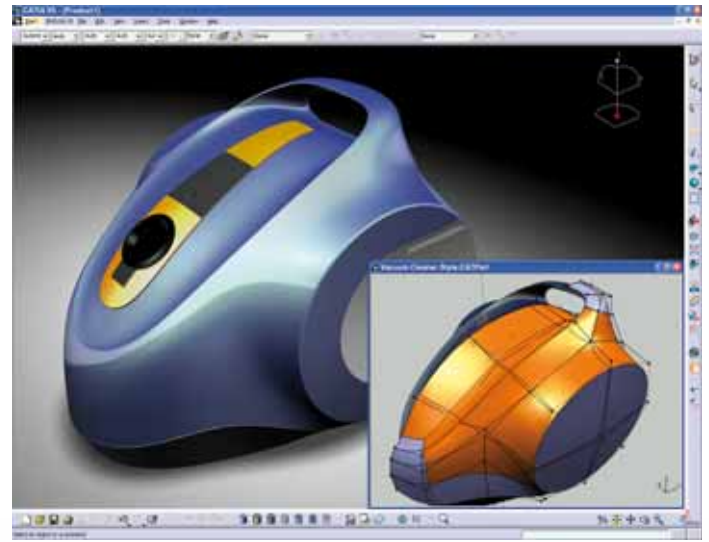

**OPTIMIZE
&
REVIEW**

Review & Optimize Engineer

Today's manufacturing industry demands extensive use of analysis and simulation for better product assessments earlier in the design process. CATIA PLM Express offers a broad portfolio of capabilities, fully integrated within the design environment, to optimize the product packaging, strength, or ergonomics. Its powerful finite element modeling and analysis solutions cover a wide range of analysis processes, while its knowledge-based architecture facilitates product optimization. With CATIA PLM Express, engineers are connected to make quick and efficient decisions with advanced collaborative reviews directly in the 3D design environment.

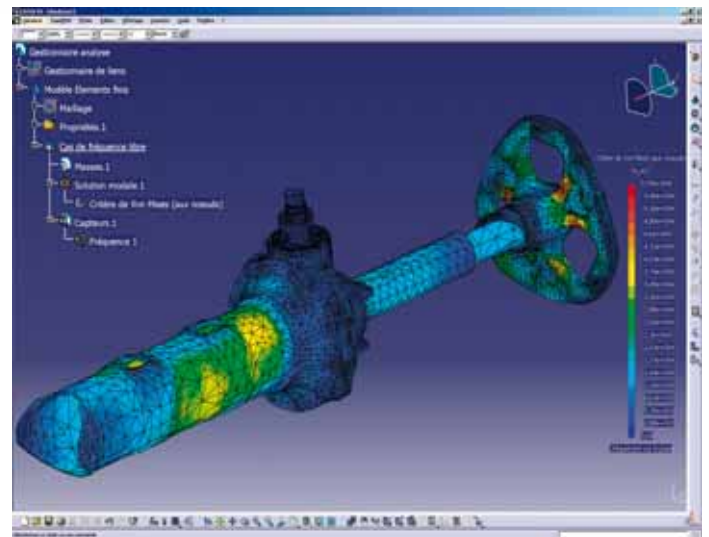

Business Challenges



Mechanical Product Engineer

Manufacturing companies need to design and deliver the right products to eager customers in less time than ever before. Engineers and designers need to complete tasks in minutes, instead of hours or days, and to design products right the first time. CATIA PLM Express fosters the design of fabricated, molded, casting, forged,

machined or even composites parts by delivering first-class and robust tools with strong and productive modeling features. The unique and powerful spec-driven modeling approach for the creation of any type of mechanical shapes promotes efficient concurrent engineering between styling and mechanical shape design, while the ultra fast functional modeling fosters productivity and flexibility.

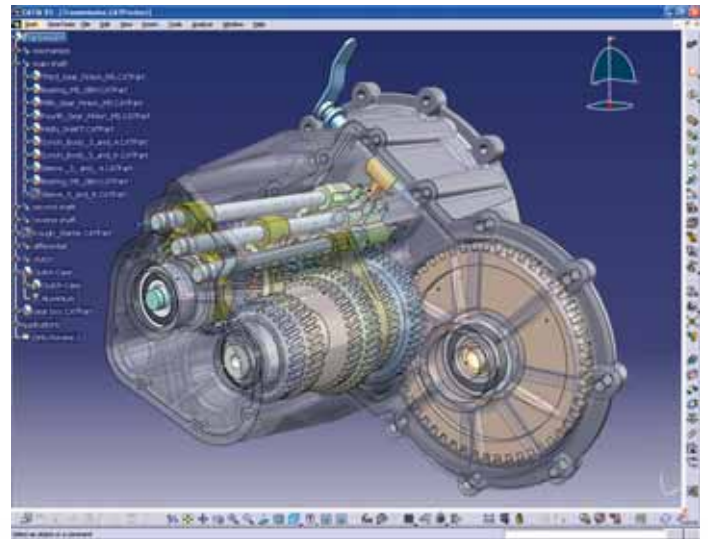

Manufacture Engineer

In order to ensure maximum product quality and manufacturing efficiency, the NC programmer needs an efficient, easy-to-use and innovative NC programming and machining simulation solution, fully immersed within the design environment. CATIA PLM Express significantly reduces overall manufacturing process time, in different manufacturing segments

(prototype, mold and die, complex aerospace parts, composites parts manufacturing etc.). Its machining solution is widely used today in all industries, in large and small companies handling 2.5-axis milling, 3-axis dedicated to mold tooling manufacture, 4- and 5-axis complex machining as well as lathe machining.

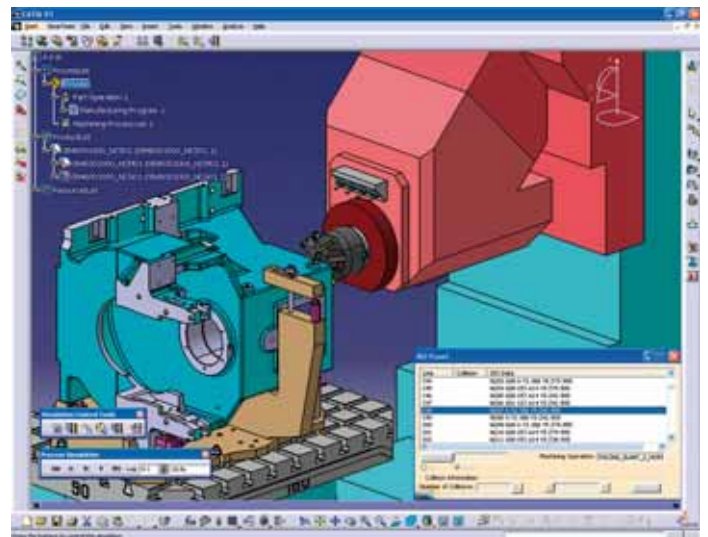



<http://www.3ds.com/my-catia-plm-express>

Visit "My CATIA PLM Express" web site,
build your own PLM solution, and request a quotation.

Dassault Systèmes (Head Office)
9, quai Marcel Dassault - BP 310
92156 Suresnes Cedex - FRANCE
Tel: 33 (0)1 40 99 40 99

Dassault Systèmes of America
6320 Canoga Avenue
Trillium East Tower
Woodland Hills,
CA 91367-2526 - USA
Tel: 1 818 999 2500

Dassault Systèmes
Pier City Shibaura Bldg 10F
3-18-1 Kaigan, Minato-Ku
Tokyo 108-0022 - JAPAN
Tel: 81 3 5442 4011



About Dassault Systèmes

As a world leader in 3D and Product Lifecycle Management (PLM) solutions, Dassault Systèmes brings value to more than 90,000 customers in 80 countries. A pioneer in the 3D software market since 1981, Dassault Systèmes develops and markets PLM application software and services that support industrial processes and provide a 3D vision of the entire lifecycle of products from conception to maintenance. The Dassault Systèmes portfolio consists of CATIA for designing the virtual product - SolidWorks for 3D mechanical design - DELMIA for virtual production - SIMULIA for virtual testing and ENOVIA for global collaborative lifecycle management, including ENOVIA VPLM, ENOVIA MatrixOne and ENOVIA SmarTeam. Dassault Systèmes is listed on the Nasdaq (DASTY) and Euronext Paris (#13065, DSY. PA) stock exchanges. For more information, visit <http://www.3ds.com>

CATIA, DELMIA, ENOVIA, SIMULIA and SolidWorks are registered trademarks of Dassault Systèmes or its subsidiaries in the US and/or other countries.

Pictures courtesy: Dassault Systèmes, Krasnoyarsk Combine Harvester, Estech, Integral Powertrain, Wook II Machinery CO. Ltd, Dassault Aviation, Bobst SA, Seaway, Dassault Aviation / Philippe Stroppa/ GAMMA, Sidel, Hélicoptères Guimbal, Darmstadt University, SDMO, Quadro Consulting, Smoby.



www.3ds.com