

Topology Optimization of Nacelle Components with ATOM

Ahmet T. Becene Ph.D.

Goodrich Corporation

Weight reduction of components and systems is of utmost importance in Aerospace industry. Reducing weight translates into higher performance and lower fuel consumption. In this paper we identify two components as candidates for weight reduction. In order to achieve this goal without sacrificing the current performance of these components we use ATOM optimization software within Abaqus environment. Current geometry models are simulated with the specified load cases to establish a baseline performance in term of stiffness and stresses. We then generate design envelopes representing the available space for topology optimization. Same load cases are applied to the optimization models with weight upper limit constraints and minimum strain energy objective functions. Optimization results suggest 10% average mass reduction when compared to the current components with significant increase in stiffness.

1. Introduction

Decreasing component weight while achieving same or better performance in terms of stiffness and durability is a primary goal in the Aerospace industry. Reduced component weights result in lower fuel consumption and higher cargo and passenger capacities. Traditional design techniques fall short of achieving these goals due to time consuming nature of the design-analyze-modify cycle. Free optimization techniques such as Topology Optimization provide optimal initial designs and significantly reduce the engineering time. Recent developments in this field resulted in easy to use software with CAD enabled outputs and robust smoothing techniques. Today, optimization techniques are widely used in the industry, from components as small as MEMS (C. F. Lin, 2006) to as large as wind turbines and aircraft (L.Krog, A. Tucker, 2004).

2. Nacelle Structure

The nacelle is the housing that covers and holds the engine and systems. Main components of a turbofan engine nacelle (Fig 1) are

- 1- Inlet cowl
- 2- Fan cowl
- 3- Thrust reverser
- 4- Exhaust cone and nozzle

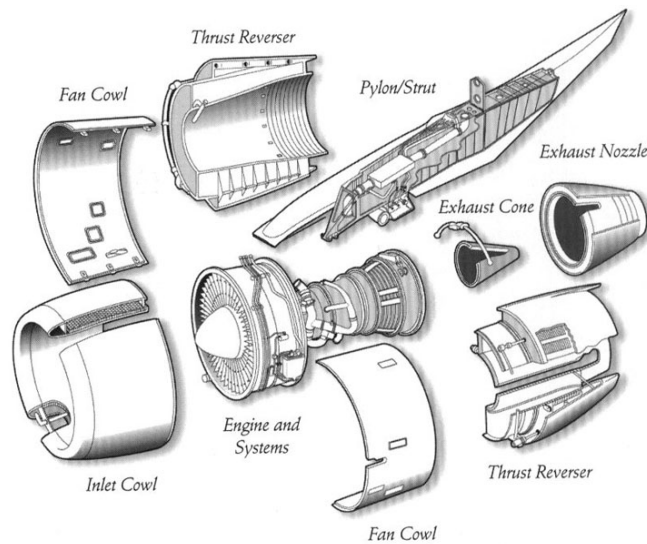

Figure 1. Nacelle assembly main components

Within these main components several sub-systems and components are housed. Weight reduction in these systems allows for further weight reduction in the support structure, such as the pylons and the wings. As the aircraft manufacturers use larger fan diameter Geared Turbofan engines the size and the weight of the nacelle components also increase (Fig 2). Metal structures in these components are natural targets for topology optimization studies and good candidates for weight reduction. In this paper we study two such structures, namely the hinges and the latches from the fan cowl component.



Figure 2. Goodrich thrust reverser for the Boeing 787 Dreamliner

Fan cowls are attached to the nacelle assembly using latches and hinges. These components are under many different loads, such as open panel wind loading and aerodynamic pressure loading. They must perform their intended tasks reliably since a failure during flight may jeopardize the safety of the aircraft.



Figure 3. Metallic hinges attaching the composite fan cowl to the main structure

A through mathematical treatment of the optimization problem is given in Reference 4. In this paper we concentrate on two practical applications of the topology optimization method using Abaqus ATOM.

3. Problem Definition

Current geometry for the latch and hinge components (Fig 4) are designed to safely support several load cases. Dimensioning of these components are conducted with hand calculations and traditional Finite Element Analysis models. This approach yields to manufacturable components using traditional operations. With topology optimization method we aim to reduce the weights of these components by 10% without adversely affecting their stiffness and strength. In order to minimize the impact to the current assembly, their interface to the existing structure, such as the mating surfaces and bolt down locations must remain the same.

Loads transferred to the latches and hinges from the fan cowl panels are quantified as concentrated loads at the interface surfaces, distributed with rigid elements (Fig 5). Bolt down locations are treated as fixed boundary conditions. Multiple load cases are included during the optimization runs (Table 1). Magnitudes of these loads are not explicitly shown in this paper.

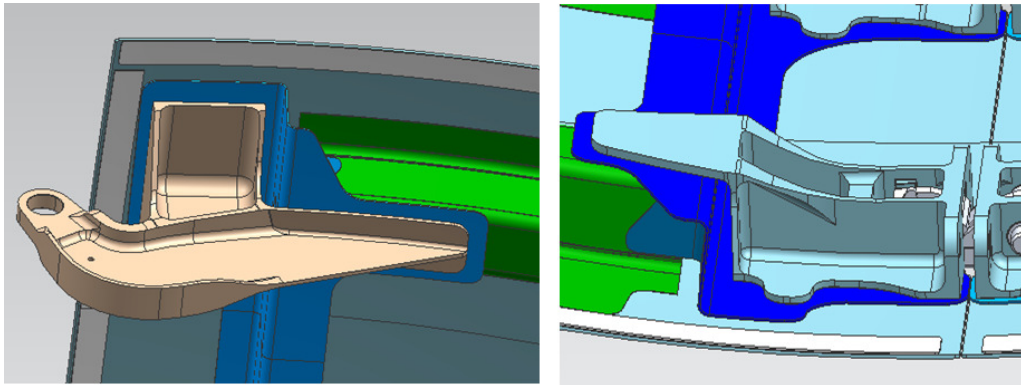

Figure 4. Current geometry for the hinges (left) and latches

Case	Load Condition	Fx (lbf) (Hoop)	Fy (lbf) (Radial)	Fz (lbf) (Fwd-Aft)
Max Fx	FBO	Fx1	Fy1	Fz1
Min Fx	FBO	Fx2	Fy2	Fz2
Max Fy	Peak Burst Duct (PBD)	Fx3	Fy3	Fz3
Min Fy	PBD	Fx4	Fy4	Fz4
Max Fz	FBO	Fx5	Fy5	Fz5
Min Fz	FBO	Fx6	Fy6	Fz6
Max Fr	PBD	Fx7	Fy7	Fz7

Table 1. Included load cases in the optimization studies

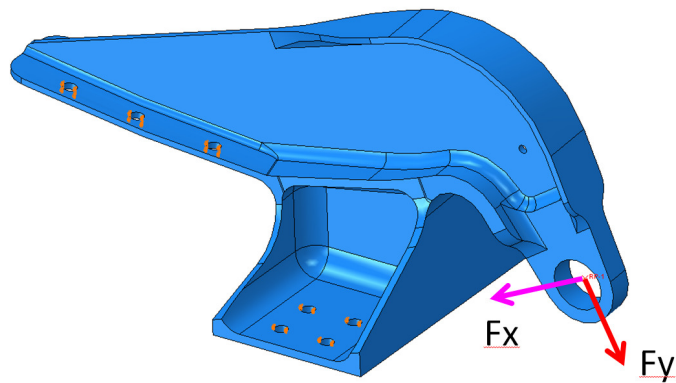

Figure 5. Loads on the hinges

Design space solids are generated for the hinge and latch studies (Fig 6). In order to achieve a globally optimum solution it is important to include as much volume as possible in the design space solids. Bolt down locations and interface surfaces are designated as frozen regions. These regions are ignored by the optimization routine and remain the same through the simulations. Rest of the solids are partitioned and designated as design regions.

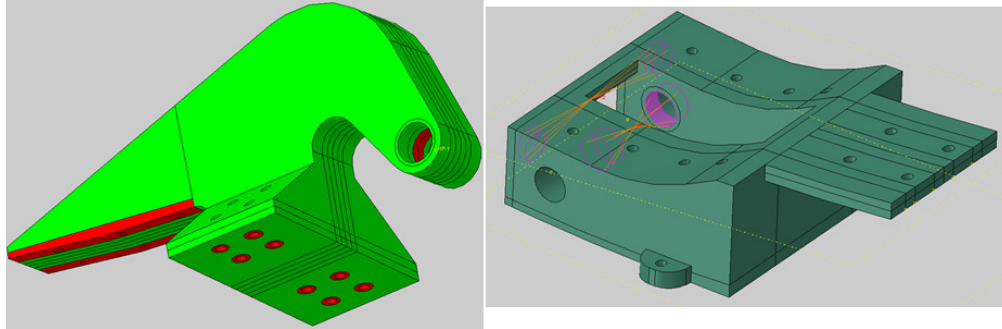

Figure 6. Design space solid for hinge (left) and latch

Total of two design responses generated for both simulations:

- Strain Energy Response
- Volume Response

Strain energy response is treated as an Objective Function to be minimized while the Volume Response is treated as a Constraint with less than 22% of the initial design space volume desired as the limit. This value corresponds to ~10% weight reduction when compared to the current geometry. Minimization of the strain energy is equivalent to minimizing the compliance of the geometry, which is the maximum stiffness condition. A Geometric Restriction, such as symmetry or member control is not included in the optimization simulations.

4. Results and Conclusions

Both simulations ran for 30 iterations on a Core i7 870 CPU with 8 cores running at 2.93GHz and with the cpus=8 option. Hinge model included 38517 nodes and 25039 Tet10 elements. Total simulation time for the hinge model was approximately 155 minutes. Results are post-processed in Abaqus/Viewer. Upon satisfactory results, a smoothed surface mesh is extracted from both configurations in Abaqus input format (Fig 7 & 8). These mesh files are imported into Abaqus/CAE and Tet meshed using the Edit Mesh / Convert Tri to Tet utility. Appropriate loads and boundary conditions are transferred to the Tet meshes for verification runs (Fig 9). Verification run results provided the comparison to the existing geometry baseline results. Material properties remained the same for current and optimized geometry simulations.

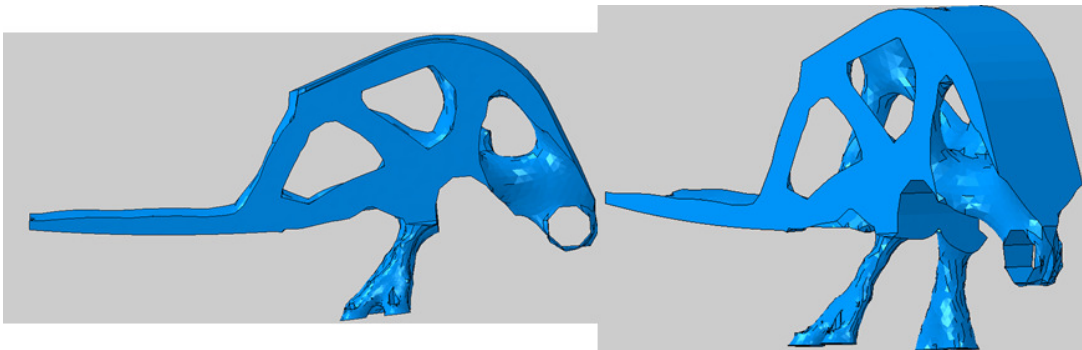

Figure 7. Optimum material distribution for the hinge component

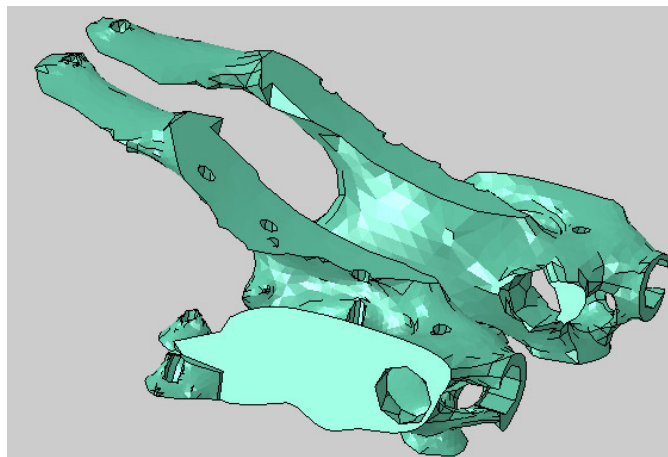

Figure 8. Optimum material distribution for the latch component

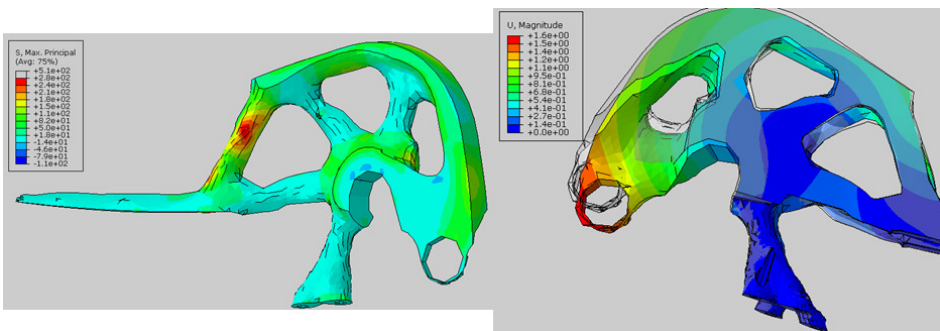

Figure 9. Verification simulation results for the hinge component

Results in terms of mass reduction, stiffness increase or stress decrease are shown in Table 2. The topologies of the optimized geometry do not lend themselves to easy manufacturing due to their “organic” configuration. In order to take full advantage of the topology optimization studies an advanced manufacturing method such as Additive Manufacturing must be employed. manufacturing methods are not capable of generating the resultant geometry without excessive added cost. If advanced manufacturing methods are not available, topology optimization results can be used as baseline for further design iterations or certain manufacturing constrains can be applied to the optimization simulations in terms of geometrical restrictions.

Component	Weight	Stiffness	Max. Stress
Hinge	7% Reduction	56% Increase	No change
Latch	10% Reduction	235% Increase	15% Reduction

Table 2. Optimization summary

5. References

1. Waqas Saleem, Hu Lu, Fan Yuqing, "*Topology Optimization Problem Formulation and Pragmatic Outcomes by Integration of TOSCA and CAE Tools*", Proceedings of the World Congress on Engineering and Computer Science, 2008
2. L.Krog, A. Tucker, Martin Kemp, Richard Boyd, "*Topology Optimization of Aircraft Wing Box Ribs*", 10th AIAA/ISSMO Multidisciplinary Analysis and Optimization Conference, 2004
3. C. F. Lin and C. J. Shih, "*A Post-Design of Topology Optimization for Mechanical Compliant Amplifier in MEMS*", Tamkang Journal of Science and Engineering, Vol. 9, No 3, pp. 215-222, 2006
4. M. P. Bendsoe., O. Sigmund, "*Topology Optimization, Theory Methods and applications*", Springer Verlag ISBN 3-540-48992-1, 2003