

CATIA Version 6 Release 2012x - FACT SHEET DIGITAL PRODUCT EXPERIENCE

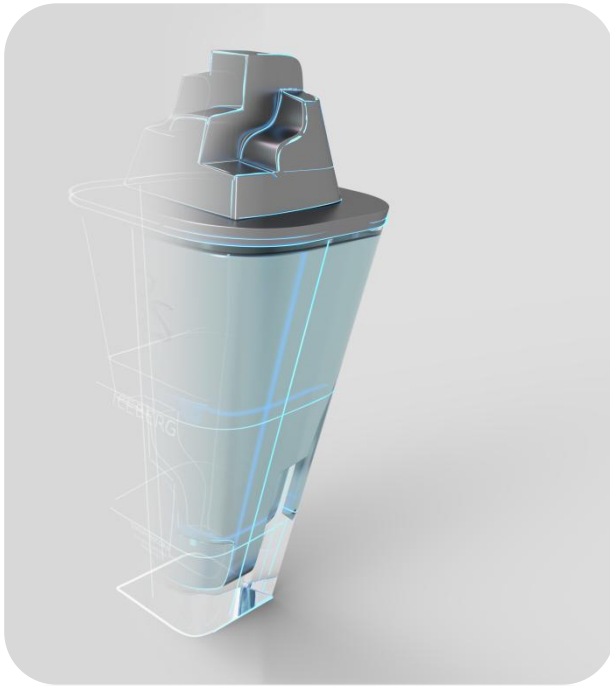

CATIA Natural Sketch

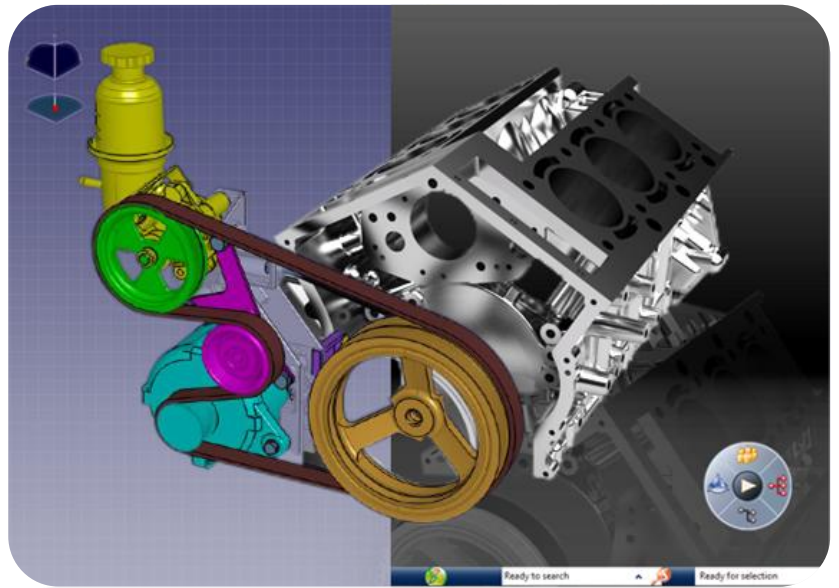

CATIA Version 6-V5 Compatibility

VALUE AT A GLANCE

CATIA Version 6 AND Version 6 Release 2012x OVERVIEW

CATIA Version 6 DOMAINS AND Version 6 Release 2012x ENHANCEMENTS

WHERE TO FIND MORE INFORMATION

VALUE AT A GLANCE

CATIA Version 6 LEVERAGES THE CAPACITY OF INNOVATION FOR COMPANIES OF ALL SIZES IN ALL INDUSTRIES BY DELIVERING BREAKTHROUGH PRODUCTIVITY DESIGN SOLUTIONS POWERED BY A HIGHLY COLLABORATIVE PLATFORM.

CATIA Version 6 redefines CAD from the purely physical product definition and expands it from digital mock-up to functional mock-up taking into account the multiple views that necessitates the product development (i.e. requirement, functional, logical and physical). Designed to operate on a PLM 2.0 platform, CATIA Version 6 is a 3D collaborative solution linking designers and non-CAD specialists.

CATIA Version 6 OVERVIEW

GLOBAL COLLABORATIVE INNOVATION

Broaden CATIA usage beyond designers to casual users within and outside the engineering department. Ground-breaking collaboration tools enable 3D brainstorming within the community of PLM users, to reach a new level of innovation.

LIFELIKE EXPERIENCE

CATIA introduces a paradigm shift to enable first- life experience and bring 3D product design to life with unmatched realism. In addition, CATIA Version 6 offers compelling simplicity and efficiency with in-context 3D manipulators and natural 3D operations.

SINGLE PLM PLATFORM FOR IP MANAGEMENT

Harnesses collective intelligence, making the always up-to-date product definition accessible to the various communities from anywhere, at any time. Facilitates multi-discipline collaboration among designers, engineering users, and manufacturing users from one unique IP repository, making the company knowledgeware assets available for all participants.

ONLINE CREATION AND COLLABORATION

Reaches new disciplines with CATIA Systems and widens the traditional scope of CATIA to the requirements, functional, and logical views of the physical product in a collaborative manner. This allows for direct traceability of the product, from the beginning to end phases of creation. CATIA Version 6 delivers PLM objects that match collaborative design innovation, eliminating heavy assembly files, enabling true concurrent design, and eliminating the needs for high references management between part, drawing, and products.

READY TO USE PLM BUSINESS PROCESSES

Opens new opportunities for new industries such as consumer packaged goods, consumer goods, and high tech. The CATIA product portfolio continues to cover more industry processes.

LOWER COST OF OWNERSHIP

Protects the V5 investment; as a natural extension to V5, CATIA Version 6 ensures a smooth upgrade and short ramp-up from V5 to V6. There is an easy transition to V6 with the use of the same modeler and ready-to-use migration path.

Version 6 Release 2012x OVERVIEW

CATIA SYSTEMS

Increased control and visibility throughout the requirements engineering process for complex systems

A new Traceability Matrix provides an “all in one” Systems View which captures, manages and displays all relationships in the RFLP Systems Breakdown., enabling rapid understanding of current requirement fulfillment.

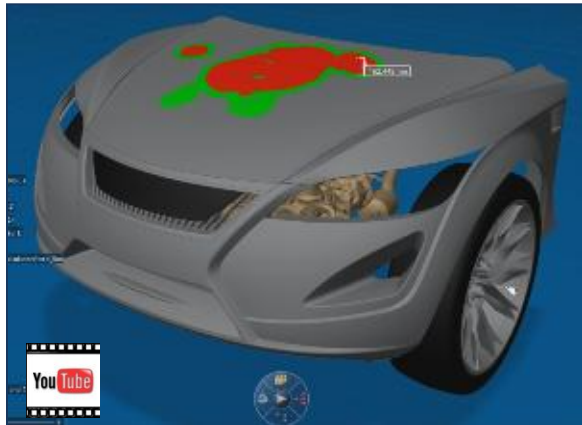

Requirements Management of complex products with large volumes of requirements is simplified through the introduction of new grouping and analysis capabilities.

Reviewers can now collaborate on Requirements in addition to Functional, Logical and Physical entities, while designers can directly access the requirement that is satisfied by a given feature of a physical product.. This ensures improved communication and project awareness.

Increased development agility with the rapid definition, simulation and analysis of complex systems behavior

Animations are enriched through the display of dynamic symbols in simulations, improving the overall understanding of systems behavior Assembly & positioning of the 3D logical model can reuse behavior simulation results, enabling the faster conceptual development of 3D systems.

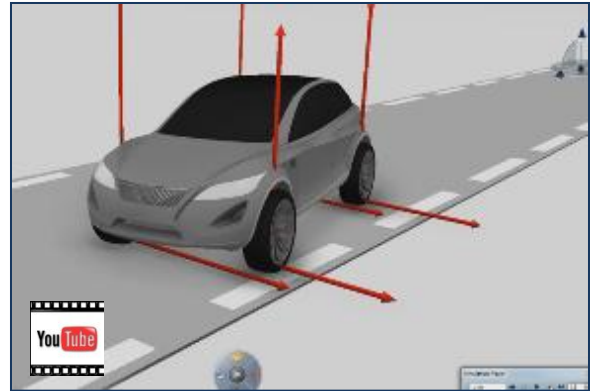

Executable models are more easily shared for simulation on other computers. Export options enable the generated model to be executed on any computer free of any licensing.

Reuse of Knowledge and Catalogs optimizes the systems design process

Faster systems architecture definition and trade-off studies, with the pre-selection of relevant sub-systems catalogs or resources, ensures compliance with international or company standards.

CATIA SHAPE

Unique breakthrough technology which revolutionizes the way creative designers express and communicate their design intent

Natural Sketch brings to creative designers a new level of expression, creativity & communication via 3 unique user experiences, allowing them to:

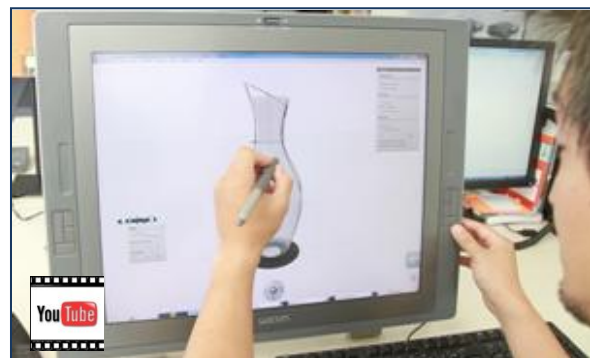

Sketch in 3D to express & communicate their creative ideas
Transform their 2D idea into a 3D reality

Explore detailed design by sketching on 3D objects

CATIA MECHANICAL

A Unique new compatibility enables seamless Live Collaboration between CATIA Version 6 and V5

3D Models created in CATIA Version 6 can be sent to V5, retaining their core features. These features can be modified directly in V5.

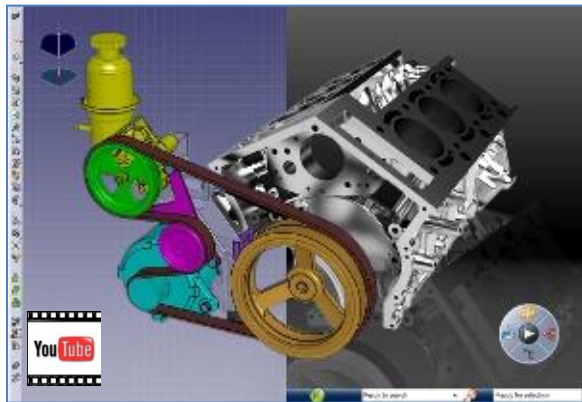

A design can now evolve iteratively, with engineers having the freedom to create and modify the part at the feature level, whether they use CATIA V5 or Version 6.

Enrichment and completeness of industry process coverage delivers productivity gains.

Plastic Mold Tool design time reduced by 60% with improved Template-based design approach.

New capability to create and manage Welding and Glue beads ensures concurrent engineering, their management with configuration and versioning and simplifying re-use.

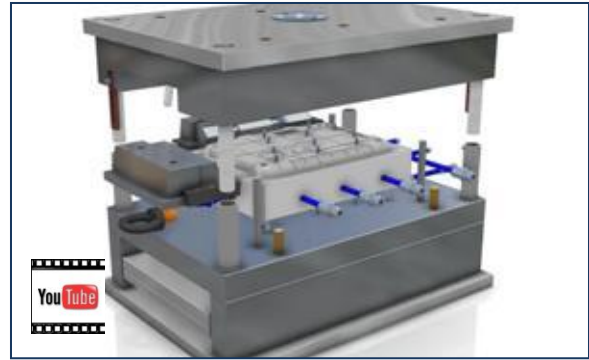

With new functionalities, such as constraints, patterns and mirroring, most sheet metal product can now be designed completely within Bend Part Design. This product increases affordability and provides a more life-like experience to the designer.

Automation gains accelerate complex product modeling

Families of components or assemblies are now easily editable and shareable and can be automatically built from spreadsheet templates. This brings automation to the lifecycle management of component families and increases flexibility to changes, versioning and variants.

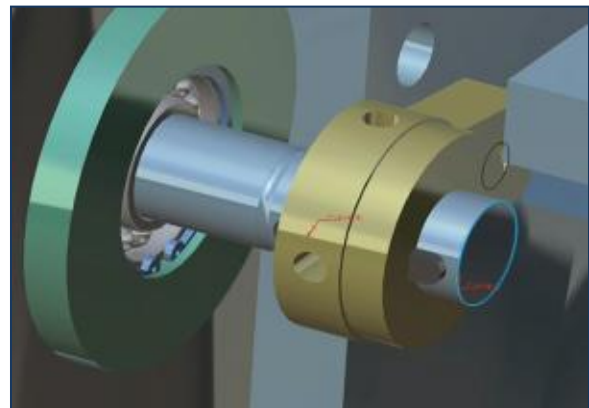

CATIA Automated Design Process benefits from a key extension to the Enterprise Knowledge Language, reaching a new level in object modeling, generation and automation. This brings additional flexibility to the domain expert, who can now combine the two complementary approaches for product automation: interactive, through process or design capture, and/or language based, to the level of ICAD.

Performance gains in Functional Modeling and real time editing in CATIA Live Shape

Major performance improvements increase the update performance of Functional Modeling for plastic part definition.

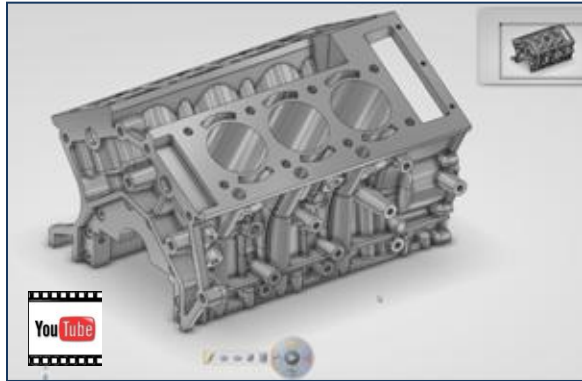

Performance enhancements to Live Shape enables real-time editing for local changes to very large and complex products.

Constraints, patterns and mirroring functionalities in Bend Part design

With new functionalities, such as constraints, patterns and mirroring, most sheet metal product can now be designed completely within Bend Part Design.



This product increases affordability and provides a more life-like experience to the designer.

CATIA EQUIPMENT

Flat cables geometry management for 3D wire harness design

CATIA 3D Electrical Design product takes benefit of the “flex algorithm” from Simulia to introduce a new, dedicated 3D representation for flat cables, which notably handles the torsion of the cable's profile all along its center curve.



The creation and management of 2D folds on flat cables makes it possible to design flat cables with a more realistic behavior, increasing the model's quality and comprehension.

Complex harness design and flattening can now proceed more concurrently

CATIA Version 6 allows electrical designers to upgrade their current harness design process, leading to important productivity improvements in the Downstream Preparation for manufacturing. Complex harness design and flattening can now proceed more concurrently, with sections or zones of the harness being extracted and flattened as the design evolves.

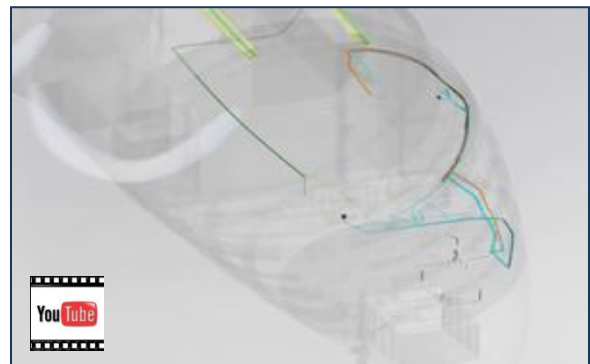

There is no need to wait for the complete harness design to be finalized before proceeding with the flattening step. This way Layout management task which is extremely time consuming can now be started early in the process.

ECAD - CATIA collaboration with exchange of the board layers & conductors definition

CATIA Printed Circuit Board Design now enables you to take into account all the geometry of the board, in order to ensure right first time design , and to reduce physical prototypes. The product now supports the Import & Export of IDF files including the definition of layers and conductors, and their electrical properties.

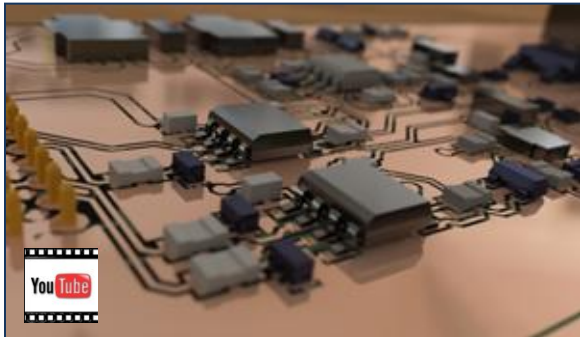

The modeling of detailed 3D circuit board conductors & layers is very useful for downstream analyses such as Voltage drop

simulation, Heat flow or electromagnetic interference. It also improves the accuracy of the circuit board representation in the virtual product, removing issues related to mechanical design integration.

Greater Openness for equipment engineering through improved support of industry exchange standards

The CATIA KBL Export function enables to export CATIA 3D electrical Systems & geometry into the KBL neutral format file.

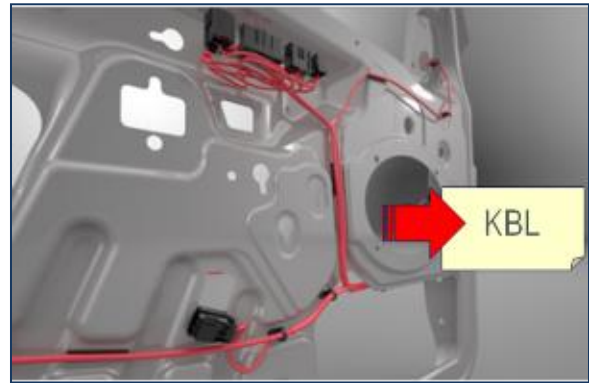

Export to KBL format is needed for data exchange between car manufacturers and specialized wire harness manufacturing suppliers, to support collaboration scenarios.

CATIA Version 6 DOMAINS AND Version 6 Release 2012x ENHANCEMENTS

CATIA SYSTEMS

Across industries, products are getting increasingly complex, involving many more engineering disciplines, with the value shifting from the products themselves to the actual services demanding customers expect from these products.

REQUIREMENTS ENGINEERING

The effective requirements engineering of complex products and systems ensures compliance to regulations and specifications, at the same time it improves time-to-market and helps reduce overall costs. It allows organizations to capture the “voice of the customer and translates that information into new products and systems in a timely and efficient manner.

SYSTEMS ARCHITECTURE

Delivering complex products and systems demands an open, extensible and versatile approach to system architecture definition, development, integration to modeling and simulation environments, as well as full lifecycle management of the underlying architecture entities and artifacts.

SYSTEMS MODELING & LIBRARIES

Today it is common practice to use many different models to simulate the behavior of complex systems and products. The challenge with this approach is that these models rarely interoperate with one another and do not exist in an aggregated environment for a ‘whole-system multi-physics simulation’ of the complete product. The Dassault Systèmes (DS) solution set provides a fully integrated systems modeling environment that leverages the open Modelica language as well as logic state machine based simulations.

EMBEDDED SYSTEMS SOFTWARE

Our embedded software management capabilities enables system architect to define, simulate and generate C-code for any control systems. The compiler is based on a technology, which is widely used in aerospace industry, to produce safety critical embedded software. Our solution comes with a set of editors including Grafcet, Statechart and Dataflow to enable components re-use as well as dynamic type and unit propagation.

Major V6R2012x ENHANCEMENTS FOR CATIA SYSTEMS:

Simplified Requirements Management for Large and Complex Systems

Requirements Management of complex systems with large volumes of requirements is simplified through the introduction of new grouping and analysis capabilities.

Rapid understanding and management of requirements fulfillment

A new Traceability Matrix provides an “all in one” Systems View which captures, manages and displays all relationships in the RFLP Systems Breakdown., enabling rapid understanding of current requirement fulfillment Live Validation on requirements.

Collaborative Review on Requirements

Reviewers can now collaborate on Requirements in addition to Functional, Logical and Physical entities, while designers can directly access the requirement that is satisfied by a given feature of a physical product.. This ensures improved communication and project awareness.

Enriched animation through the display of dynamic symbols during the model simulation

Animations are enriched through the display of dynamic symbols such as force arrows or springs in simulations, improving the overall understanding of systems behavior.

Fast assembly & positioning of the 3D logical model using simulation results

Assembly & positioning of the 3D logical model can reuse behavior simulation results, enabling the faster conceptual development of 3D systems.

Export executable models for simulation on any computer

Executable models are more easily shared for simulation on other computers. Export options enable the generated model to be executed on any computer free of any licensing.

Reuse of Knowledge and Catalogs optimizes systems design process

Faster systems architecture definition and trade-off studies, with the pre-selection of relevant sub-systems catalogs or resources, ensures compliance with international or company standards.

Navigation through hyperlinks from physical components to requirements

Designer can provide an automatic traceability between a specific sub-part of a physical design back to the requirement it satisfies. The designer can annotate a feature, a specific area or a piece of construction geometry, and link it through a hyperlink to a requirement stored in the database. This ensures that a specific company know-how or design intent associated to a precise feature of the product is not lost and can be shared by other users.

Numerous editor ergonomics enhancements bring productivity and flexibility when designing a systems architecture

User benefits in particular from grid support to get an efficient layout of the system decomposition. Other ergonomics enhancements, such as balloons, back/next buttons or numerous improvements of the 2D graph display, make it more workable.

Quick access to the flows and system types

To analyze efficiently the selected functional or logical definition, the flows and the system types manipulated in the definition are clearly listed in a table from which they can be edited (attributes, structure edition). This spreadsheet editor allows a more efficient edition through an easy customization of the display, ordering or filtering the more relevant columns and storing these preferences.

CATIA SHAPE

CATIA Shape provides industrial designers, Class A modelers, and mechanical engineers with a full suite of surfacing, reverse engineering, and visualization solutions to create, modify, and validate any type of complex innovative shapes and help streamline the transition and collaboration between Design, Class A and Engineering departments. From subdivision, styling, and Class A surfaces to mechanical functional surfaces, CATIA Shape covers all the surface creation and modification needs. It also supports the complete reverse engineering process from the import of digitized data to the recovering and finalization/completion of high quality surfaces.

INDUSTRIAL DESIGN

Combining a unique and intuitive virtual clay modeling approach with free-form surfaces, CATIA Shape is at the service of industrial designers and their creativity. Starting 3D ideation from scratch or from 2D sketches, industrial designers can manipulate shapes with unrivaled freedom, but also take full advantage of a true creativity accelerator to quickly explore and test many more ideas in the early conceptual phase. CATIA Shape also provides real-time visualization for instant evaluation and photorealistic Mental Ray rendering, allowing designers to make better and faster decisions

SURFACE REFINEMENT (CLASS A & LOFTING)

CATIA fully addresses the Automotive Class-A process with a solution for surface refinement that integrates industry leading ICEM surfacing technologies. By combining the V6 technology strengths, which include knowledge capture-and-reuse paradigm, it delivers a powerful and intuitive suite of tools for modeling, analyzing and visualizing aesthetic and ergonomic shapes for the highest Class-A surface quality.

MECHANICAL SURFACES

CATIA Shape provides advanced technologies for mechanical surfacing, based on a powerful specification-driven modeling approach. This solution brings high-end quality surface modeling for detailed designers and promotes efficient concurrent engineering between styling and engineering worlds in order to optimize the product design workflow.

COMPOSITES

Spanning from preliminary to engineering detailed design and manufacturing preparation, CATIA Shape provides unique capabilities for designers of composites structures to work in dedicated design in-context environments to integrate structural, assembly, and manufacturing requirements early in the composites design process and thereby anticipate and avoid problems.

Key V6R2012x ENHANCEMENTS FOR CATIA SHAPE:

Natural Sketch delivers a new paradigm that revolutionizes the translation of creative intent into the digital product

Simplicity and ease of use enable the rapid capture and communication of ideas, freeing the creative mind of designers and transforming the innovation process. Natural Sketch captures the gestures of the creative designer while they sketch naturally with a digital pen. The sketch is captured directly in 3D, ensuring the transition from a 2D idea to a 3D digital product, while retaining design intent. The designer can continue to sketch directly on the 3D model to develop creative and accurate design exploration and variations.

New positioning matrix tool in CATIA Distiller

You can now use the new positioning matrix tool to choose different local axis systems for products containing several representations. When you open the 3DXML file of the distilled product in 3DVIA Studio, each representation the local axis system is the one you have defined previously in CATIA Distiller.

PowerFit associativity for reverse engineering

This enhancement brings associativity to the PowerFit command. It is now possible to replace the cloud by a new one or to change parameters, and the PowerFit object will be automatically updated. This improvement will enhance user productivity in the surface reconstruction process.

Reverse Engineering' Surface Network command enhancement with automatic G0/G1 transition to increase user productivity

When using the Surface Network command, it could be tedious to set manually the transitions between loops, especially in case of many loops in the network (for example, a ship hull). Transitions are now computed and initialized automatically at the network selection step. Of course, you still have the ability to modify them interactively. For best homogeneity and visibility,

2D immersive icons replace the 3D arrows transitions symbols to offer the best interactive location feedback when manipulating the point of view.

Enhanced Sectioning ergonomy for Functional Shape Design

This provides easier and more efficient use of the Sectioning mode in the 3D Edit function with tools to manage the section view and the Sectioning mode exit. Sectioning mode is a powerful tool to edit existing features in the FSE workbench and this improvement will make this version faster and easier.

New Dimple Function for Functional Shape Design

This enhancement makes it possible to create a Dimple at a given point using the Functional Shape Design workbench. This new function can be considered as a punctual stiffener, whereas the bead is a linear stiffener.

Permanent Unfold distortion analysis for Developed Shapes

This new behavior integrated to the Unfold function allows the user to display the distortions map directly in the main 3D viewer instead of the classical dedicated and separated viewer. This display can be permanent. This option allows you to see directly the distortions in the 3D space, in the design context, and to map back the distortions either in the folded or unfolded view.

New Contour command in Generative Shape Design Workbench

Rapidly create a closed contour from a set of wires (intersecting or not) on a support surface using this new command in the GSD workbench. This new feature is able to extrapolate wires within a given tolerance when wires are not intersecting and to compute closed contour laying on the input support surface. Users of the composite workbench can create a contour in the GSD workbench itself, thus reducing frequent switching between two workbenches.

Rough offset for thin part in Generative Shape Optimizer product

Certain customers require the application of small offsets on plastic parts, but geometrical complexity does not allow the exact offset. These shapes are small-size parts (between 100 and 500 mm), for which one wishes to approach the exact offset to a very small tolerance (0.2 mm). The goal of this enhancement is to define and gather the conditions, making it possible to decrease the minimal value of the Rough Offset functionality deviation (objective is 0.2mm) to address the industrial need for offset on the plastic parts.

CATIA MECHANICAL

Finding ways to reduce design-to-manufacturing cycles and improving productivity are key priorities. CATIA Mechanical delivers a highly collaborative and flexible design environment with full concurrent engineering and high performance change management through relational design to enable the efficient definition and engineering of any type of 3D parts and assemblies, from the simplest to the most advanced. In V6, CATIA expands 3D design to user communities outside of the design office, addressing each profile with the right modeler capabilities: direct 3D modeling, geometrical surfaces handling, feature-based design and history-free functional modeling.

CONCEPTUAL DESIGN

Whether you are a casual user or a CAD-specialist, CATIA enables you to quickly create new designs or modify existing ones, even from other CAD solutions. Creating a new assembly structure becomes as easy as assembling toy building blocks. Manufacturing constraints can be embedded early on the preliminary shape, enabling downstream users to access the design and insert their specifications directly in the 3D models.

MECHANICAL SYSTEMS ENGINEERING

Based on the RFLP (Requirements, Functional, Logical and Physical) approach, CATIA fosters the collaborative definition of a product across its different views from conception to production and operation. This enables designers, engineers and system architects to define the product functional breakdown, the logical entities representing the technological solutions and the corresponding physical parts and assemblies.

PRODUCT DESIGN

CATIA enables the creation of any type of 3D part, from rough sketches up to the definition of mechanical assemblies. It provides all the tools needed to complete product definition, including functional tolerances and annotations, as well as kinematics definition. Cast and forged product design is addressed, as well as plastic or molded parts through a functional modeling approach. CATIA also covers also welding, fastening and sheetmetal processes.

TOOLING DESIGN

CATIA provides a wide range of application for tooling design, for generic tooling as well as mold and die. A rich catalog of industry-standard components is provided to automate tooling definition. Specific tools are also provided to address the needs of mold tooling injection designers.

Key V6R2012x ENHANCEMENTS FOR CATIA MECHANICAL:

Plastic Mold Tool design time reduced by 60% with improved Template-based design approach

Capitalizing the company know-how is an innovative solution for designing quickly the mold to produce a plastic product. Like all the advanced features of CATIA, sequences of actions can be capitalized in templates for an easy re-use. For instance, the mold base dimensions, the number of its pillars, their positions, the number of required screws, lifters or ejectors can be automatically computed according to the molded product dimensions.

New capability to create and manage Welding and Glue beads ensures greater concurrency and simpler re-use

In addition to concurrent engineering, their new management brings configuration and versioning, as it simplifies re-use.

With new functionalities, such as constraints, patterns and mirroring, most sheet metal product can now be designed completely within Bend Part Design

This product increases affordability and provides a more life-like experience to the designer.

New automation to the lifecycle management of component families, now easily editable and shareable and can be automatically built from spreadsheet templates

This brings automation to the lifecycle management of component families and increases flexibility to changes, versioning and variants.

CATIA Automated Design Process benefits from a key extension to the Enterprise Knowledge Language, reaching a new level in object modeling, generation and automation

This brings additional flexibility to the domain expert, who can now combine the two complementary approaches for product automation: interactive, through process or design capture, and/or language based, to the level of ICAD.

Major performance improvements increase the update performance of Functional Modeling for plastic part definition

Functional Modeling workbench ensures an effective advanced design as huge enhancements have been made on performance, demonstrated on some reference scenarios.

Performance enhancements to Live Shape enables real-time editing for local changes to very large and complex product

Live Shape enables to edit any product, coming from any CAD system without being a specialist or knowing the product history. In case of very complex products, only the local modification is displayed, enabling a real-time visualization and a great fluidity by postponing the update process.

Benefit from Macro-mechanisms for a better agility when designing a mechanism

Instead of having only one mechanism defined on the root of the product and pointing inside sub-assemblies, several sub-mechanisms are defined matching with sub-assemblies -even rigid sub-assemblies- and gathered in a macro mechanism. Flexible sub-assemblies are no more necessary and reuse of mechanisms from a version to another gets easier.

Presentation of Knowledge reports in drawings & layouts

Check results extracted by knowledge applications are directly visible in the drawings of the product. "Knowledge" information is easily shared by collaborators, either in the design office or in the manufacturing plants. Anyone can benefit from check results to get a better understanding of the product compliance to company rules.

Link and trace physical design features to system requirements

Provide automatic traceability between a specific sub-part of a physical design back to the requirement it satisfies. Designer can annotate a feature, a specific area or a piece of construction geometry, and link it through a hyperlink to a requirement stored in the database. Any user of

the V6 Functional Tolerancing & Annotation workbench can use an embedded browser to understand the relationships between requirements and physical design entities.

Weight and Center of Gravity analysis is extended to include folded sheetmetal parts

In a sheetmetal part, the weight of folded Sheet metal elements are taken into account, as well as those of other mechanical elements. The centre of gravity and the inertia matrix can also be declared or computed. In order to prevent this computation to lead to inconsistent results in the unfolded view, a warning is displayed to switch in the folded view.

Give a clear representation of the General Arrangement of a large project

Filtering products, according to a Layout or an Annotation set, is a key contributor to General Arrangement Plan (GAP) process. Therefore, by loading only a subset of the impacting assemblies, drawings can then be produced that feature a view of only one deck of a ship, presenting various accommodations and/or equipments, for example. This highlight also contributes to Interchangeability process, by helping to define the interface between 2 successive sections of a plane body, for instance.

CATIA EQUIPMENT

CATIA Equipment provides an integrated environment that enables the collaborative detailed design of electronic, electrical, and fluidic systems in context of a virtual product. While design is driven by the system logical definition to ensure conformity with product specifications, full traceability, and configuration management, knowledge rules are integrated to enable the automatic compliance to standards throughout the design process, all the way to the production of associative documentation for manufacturing. Such an integrated environment improves design quality, drastically reduces time needed for modifications, and minimizes errors.

ELECTRICAL WIRE HARNESS DESIGN

CATIA delivers a dedicated electro-mechanical, end-to-end solution for designing and documenting electrical wire harnesses in all products that include electric, electronic and electro-mechanic components. Creating electrical modules directly in the product digital mock-up reduces time, costs and part interferences. It also enables automatic creation of manufacturing documentation.

PIPING & TUBING DESIGN

CATIA provides general layout tools for intelligent placement of piping and tubing parts. A full set of routing and part placement methods allow users to choose the one that is right for a given context. The CATIA knowledge and rules management capabilities enable automation of the design process and compliance of company standards. Rules setup is easy with project standards and catalogs.

ELECTRONICS

Today's consumers require compact electronic devices with greater functionalities. To create high-quality products faster, companies need the integration of realistic Printed Circuit Boards (PCBs) inside a virtual product and simplified collaboration between mechanical and electronics specialists.

Key V6R2012x ENHANCEMENTS FOR CATIA EQUIPMENT:

Geometry management for flat cables in 3D wire harness design

The CATIA 3D Electrical Design product benefits from SIMULIA's "flex algorithm" to introduce a new, dedicated 3D representation for flat cables that notably handles the torsion of the cable's profile all along its center curve. The creation and management of 2D folds on flat cables makes it possible to design flat cables

with more realistic behavior, increasing the model's quality and comprehension.

Flattening harnesses designed by zones

Electrical harnesses designers can now design, extract, and flatten large size geometrical harnesses separately at their own pace. Thanks to a new Extract behavior, electrical linking and geometrical positioning between Geometrical bundles are maintained even if they are extracted separately. The flattened data can thus be merged progressively. This allows them to upgrade their current harness design process, enhancing their productivity as they won't need to wait till all the designers complete designing the whole Electrical Harness to be able to extract and flatten all the Geometrical Harnesses in one go.

ECAD - CATIA collaboration with exchange of the board layers & conductors definition

A printed circuit board can be composed of several layers of conductor & dielectric. CATIA Printed Circuit Board Design now enables the Import & Export of IDF 3.0 files with the definition of layers and conductors including their electrical properties. The modeling of detailed 3D circuit board conductors & layers improves the circuit board digital representation in the virtual product definition. This is also very useful for thermal simulation of the board to detect heat problems, or electromagnetic interferences.

New command to export electrical harness data in xml KBL neutral format

The CATIA KBL Export function enables to export CATIA 3D electrical Systems & geometry into the KBL neutral format file. KBL format has been defined by the automotive industry to support development processes and is already used in production to the harness data exchange with the suppliers. Export to KBL format is needed for data exchange between the car manufacturer and the wire harness manufacturing suppliers, to support collaboration scenarios.

Multiple enhancements deliver increased productivity for the piping and tubing designer

New and improved features such as smart routing, new analysis capabilities (including high precision measurement tools), as well as new 3D design modification features all contribute to the increased speed and quality of piping and tubing design.

Manual Routing Into Physical

This enhancement adds the capability to route manually a Logical Routable (Connection, Net, Logical, Net Group, Cable, and Piping Line) into a physical Electrical or Fluidic 3D Route. This will leverage significantly the flexibility of the routing solution. You will now be able to route signals either into Logical 3D or Physical 3D network. This allows to easily support industries that carry over approach with a maximum reuse of existing designs, like the automotive industry.

Live Manipulator Alignment Functionality in Rotate and Roll

This enhancement improves user Interface and intelligence for quick layout design through alignment functionality in Roll and Rotate actions in Live manipulator. It provides the user the capability to align any branch/segment and the network attached to it to any other branch/segment/line/axis. The PIN mechanism is provided for Rotate and Roll actions for punctual as well as local mode. The magnet mechanism is provided for only Rotate action for punctual as well as local mode.

Thumbnail for preview of automatic part placement assembly

As the auto part placement can be complex, it is better to have a preview by picture of this auto part to select it more easily. In Modify/Edit/Auto part function, a new thumbnail preview is added in the dialog box to select easily the auto part placement to use. Part placement becomes easier, you can now easily anticipate what piping part technology will be used before updating the 3D design with automatic part placement.

order to accelerate and secure drastically their product development processes. Design Knowledge and Re-use accelerates a company's business processes while ensuring compliance with its best practices and taking advantage of its collective know-how. It provides an access to advanced design parameterization, knowledge capture as well as optimization tools, and enables the definition of standard rules and checks for design quality assessment.

DESIGN KNOWLEDGE & REUSE

Design Knowledge & Re-use enables companies to model, capitalize and re-use the full complexity of their engineering knowledge in

For more information on the product content, come visit us at:

<http://www.catia.com/>

[You can also find us on your favorite social media:](#)

