

Multi-Engineering Modeling and Simulation

For CATIA V6 and Dymola

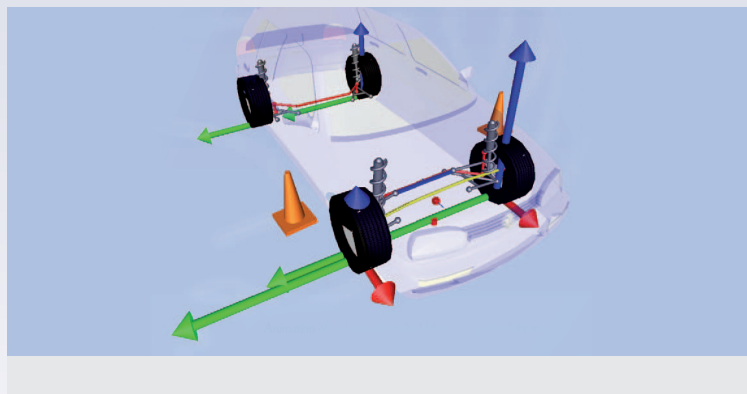

Animation of a chassis from the Vehicle Dynamics Library

OVERVIEW

- Environment for modeling and simulation of integrated and complex systems

KEY FEATURES

- Based on Modelica® standard language, a powerful, object-oriented and formally defined modeling language
- Comprehensive model libraries
- Hardware-in-the-loop Simulation (HILS), real-time on dSPACE and xPC
- Interface to Simulink®
- Real-time 3D animation and import of CAD files

BENEFITS

- Multi-engineering thanks to compatible model libraries from many engineering fields that enable high-fidelity modeling of complex integrated systems
- Intuitive modeling
- Open libraries enabling users to easily build their own components or adapt existing ones to match unique needs
- Reuse thanks to equation-oriented models that allow a component to be used in different contexts and for different studies

Multi-engineering

Dymola® has unique multi-engineering capabilities which means that models can consist of components from many engineering domains. This allows for models of complete systems to better depict reality. Libraries in many different engineering domains are available that contain components for mechanical, electrical, control, thermal, pneumatic, hydraulic, power train, thermodynamics, vehicledynamics, air-conditioning, etc.

The multi-engineering capabilities of Dymola empower users to model and simulate physical components that can be described by ordinary differential equations and algebraic equations.

Intuitive modeling

Dymola's graphical editor and the multi-engineering libraries make modeling easy. The libraries include elements corresponding to physical devices which are simply dragged-and-dropped to build the model.

Interactions between the components are conveniently described by graphical connections that model the physical coupling of the components.

This means that models are intuitively organized the same way as the physical system is composed.

Open and flexible

The Dymola environment is completely open in contrast to many modeling tools that have a fixed set of component models and proprietary methods for introducing new components. Users of Dymola can easily introduce components that match their own and unique needs. This can be done either from scratch or by using existing components as templates.

The open and flexible structure makes Dymola an excellent tool to simulate new or alternative designs and technologies. Dymola is based on Modelica, which is an object-oriented language for physical modeling developed by the Modelica Association.

Symbolic Manipulation

Dymola has unique and outstanding performance for solving differential algebraic equations (DAE).

The key to high performance and robustness is symbolic manipulation which also handles algebraic loops and reduced degrees-of-freedom caused by constraints.

These techniques together with special numerical solvers enable real-time Hardware-in-the-Loop Simulations (HILS).

Dymola is based on Modelica which gives unique access to libraries developed by leading experts around the world. All libraries are fully compatible with each other.

Modelica Standard Library

The Modelica Standard Library includes basic components and is composed of electrical, rotational, translational and multibody mechanics, thermal components, thermo-fluid flow and continuous and discrete input/output blocks. The MultiBody package provides 3-dimensional mechanical components to model rigid multibody systems, such as robots, satellites, or vehicles. The library provides basic model classes for rigid bodies, joints, forces, measurement and animation elements. Revolute and prismatic joints can be driven with elements from the onedimensional mechanics Modelica Standard library. This allows easy modeling of bearing friction, brakes, clutches and stops.

PowerTrain Library

The PowerTrain Library contains components to enable the simulation of the whole powertrain system including the resulting motion of the vehicle. This enables the prediction of attributes such as vehicle performance, fuel economy and driveability, which in turn can aid the development of the powertrain control systems and components. It is well suited for real time, hardware-in-the-loop simulation. The library provides components of varying detail to model transmissions, drivelines and the longitudinal vehicledynamics plus driver models for carrying out different tests.

Vehicle Dynamics Library

The Vehicle Dynamics Library is used to simulate vehicle dynamics behavior and handling. The library contains components such as tires, driver models, struts, wishbones, and antiroll linkages as well as complete front and rear suspensions, e.g. MacPherson, Double Wishbone and MultiLink.

Hydraulics Library

The Hydraulics Library is a powerful yet simple to use tool for the modeling of hydraulic systems using oil. Applications include machine tools, automatic transmissions, and open or closed circuit drives used in, for example, excavators or forklift trucks.

Pneumatics Library

The Pneumatics Library provides basic model classes for the modeling of cylinders and motors, valves and nozzles, lumped volumes, lines and sensors.

Air Conditioning Library

The Air Conditioning Library is a full-featured model library for refrigeration and A/C cycles with typical working media such as R134a and even CO2. It contains advanced two-phase flow and air handling models for all design phases from conceptual design to control implementation.

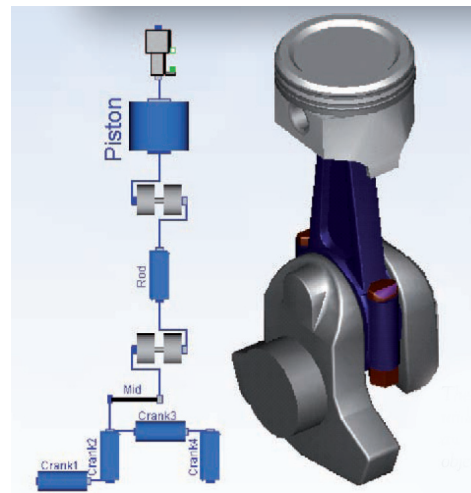

The models are easy to understand since they are built like the physical objects they represent

www.3ds.com/products/catia/portfolio/dymola

